

2

1

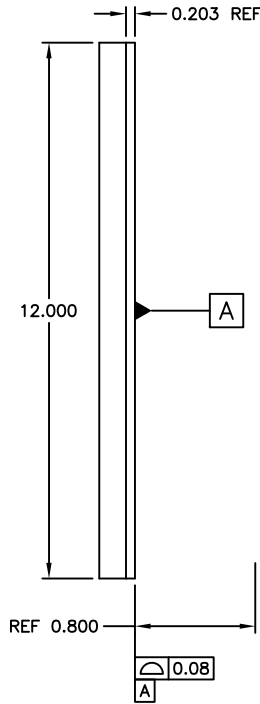

ECN NO.	PRODUCTION RELEASE	APPROVED
DATE	REVISIONS	SJO

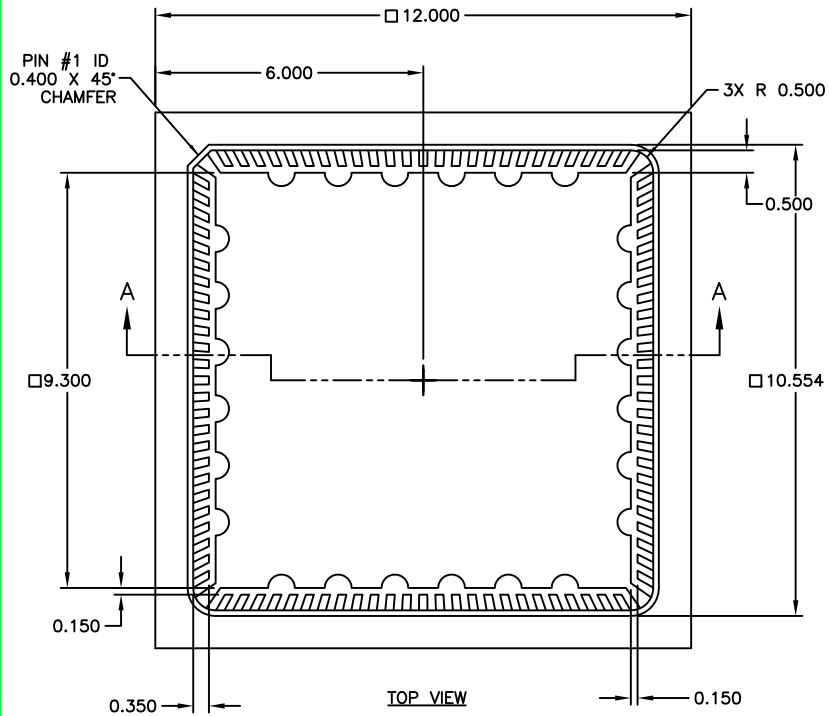
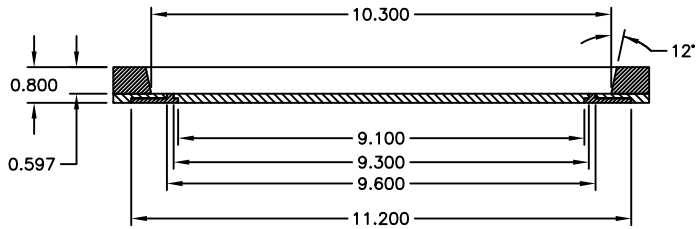
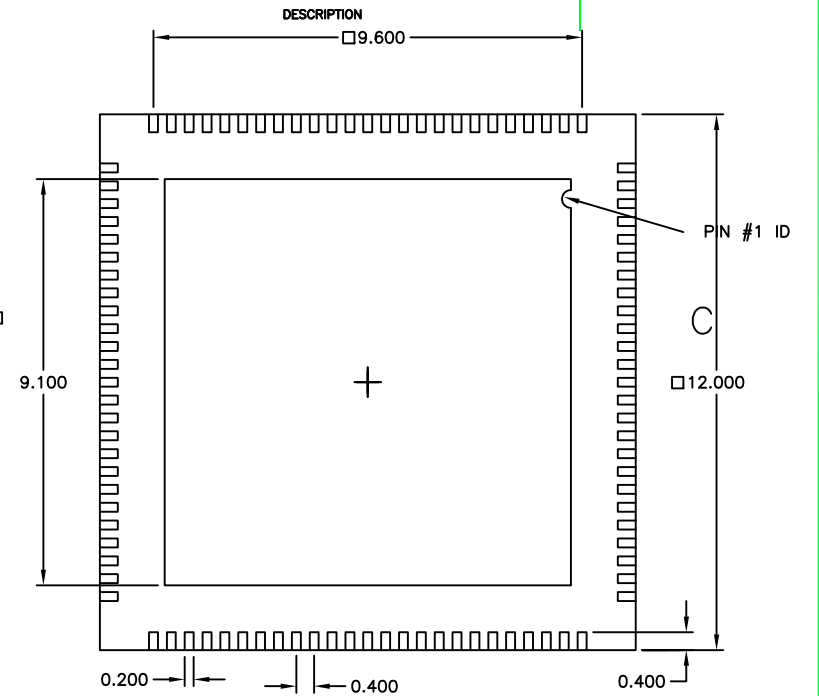

SECTION A-A

NOTES

- MATERIALS:**
LEAD FRAME: COPPER 194FH, THK = 0.203±0.008
BODY: SEMICONDUCTOR MOLDING EPOXY,
- FINISH:**
LEAD FRAME: ELECTROLESS NICKEL PER MIL-C-26074, CLASS 1, 100 TO 300 MICROINCHES (2.5µm - 7.6µm) THICK.
GOLD PLATE PER MIL-G-45204, TYPE 3, GRADE A, CLASS 1 (40 TO 80 MICROINCHES (1µm - 2µm) THICK).
BODY SURFACE FINISH: VDI 21-24 (1.12-1.6 Ra).
- PACKAGE MISMATCH:** BODY OFFSET TO LEAD FRAME = 0.076mm MAX
- UNLESS OTHERWISE SPECIFIED, RADIUS ON ALL MOLDED EDGES AND CORNERS = 0.25mm MAX.**
- PACKAGE CONFORMS TO JEDEC MO-220.**

THIRD ANGLE PROJECTION

UNLESS OTHERWISE SPECIFIED DIMENSIONS ARE IN MILLIMETER

TOLERANCES ARE:
 X.XX ± 0.15 X.XXXX ± ---
 X.XXX 0.050 ANGLES: ± 1°

DO NOT SCALE DRAWING

DRAWN BY	MWK	DATE	7/1/11
APP BY	SJO	DATE	7/1/11

MADE IN USA

Spectrum Semiconductor Materials, Inc.
www.spectrum-semi.com
 155 Nicholson Lane
 San Jose, CA 95134
 PHONE: (408) 435-5555 FAX: (408) 435-8226

12mm X 12mm
 QFN 100 LEAD OmPP

SIZE	PART NO.	REV
A	QFN10001	A1

SCALE NONE CAD FILE SHEET 1 OF 1

2

1