

REVISIONS			
ECN NO.	DATE	DESCRIPTION	APPROVED

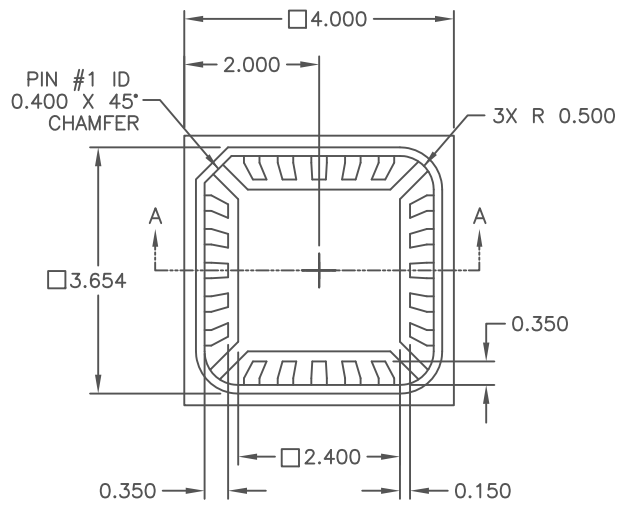

TOP VIEW

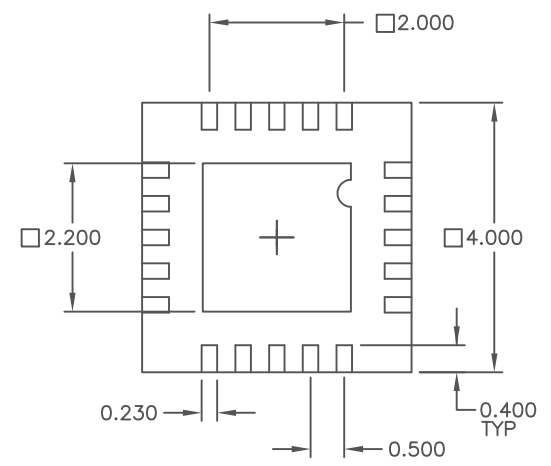
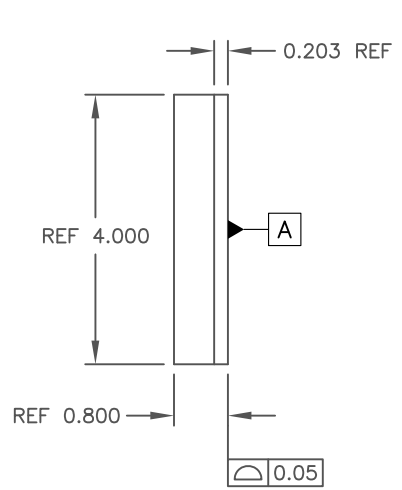

BOTTOM VIEW

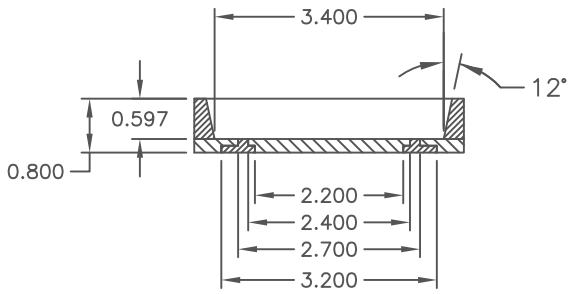

SECTION A-A

NOTES

- MATERIALS:
LEAD FRAME: COPPER 194FH, THK = 0.203±0.008
BODY: SEMICONDUCTOR MOLDING EPOXY, CONTACT SPECTRUM FOR DETAILS.
- FINISH:
LEAD FRAME: ELECTROLESS NICKEL PER MIL-C-26074, CLASS 1, 100 TO 300 MICROINCHES (2.5um - 7.6um) THICK.
GOLD PLATE PER MIL-G-45204, TYPE 3, GRADE A, CLASS 1 (40 TO 80 MICROINCHES (1um - 2um) THICK).
BODY SURFACE FINISH: VDI 21-24 (1.12-1.6 Ra).
- PACKAGE MISMATCH: BODY OFFSET TO LEAD FRAME = 0.076mm MAX
- UNLESS OTHERWISE SPECIFIED, RADIUS ON ALL MOLDED EDGES AND CORNERS = 0.25mm MAX.
- PACKAGE CONFORMS TO JEDEC MO-220.

Spectrum Semiconductor Materials, Inc.
www.spectrum-semi.com
 155 Nicholson Lane
 San Jose, CA 95134
 PHONE: (408) 435-5555 FAX: (408) 435-8226

4mm X 4mm
 QFN 20 LEAD OmPP

SIZE A	PART NO. QFN02001	REV
SCALE NONE	CAD FILE	SHEET 1 OF 1

 THIRD ANGLE PROJECTION UNLESS OTHERWISE SPECIFIED DIMENSIONS ARE IN MILLIMETER TOLERANCES ARE: X.XX ± 0.15 X.XXXX ± ---- X.XXX ± 0.050 ANGLES: ± 1'	DRAWN BY	DATE 4/19/10
	APP BY	DATE 4/19/10
MADE IN USA		
DO NOT SCALE DRAWING		