

SSM P/N LCC08426

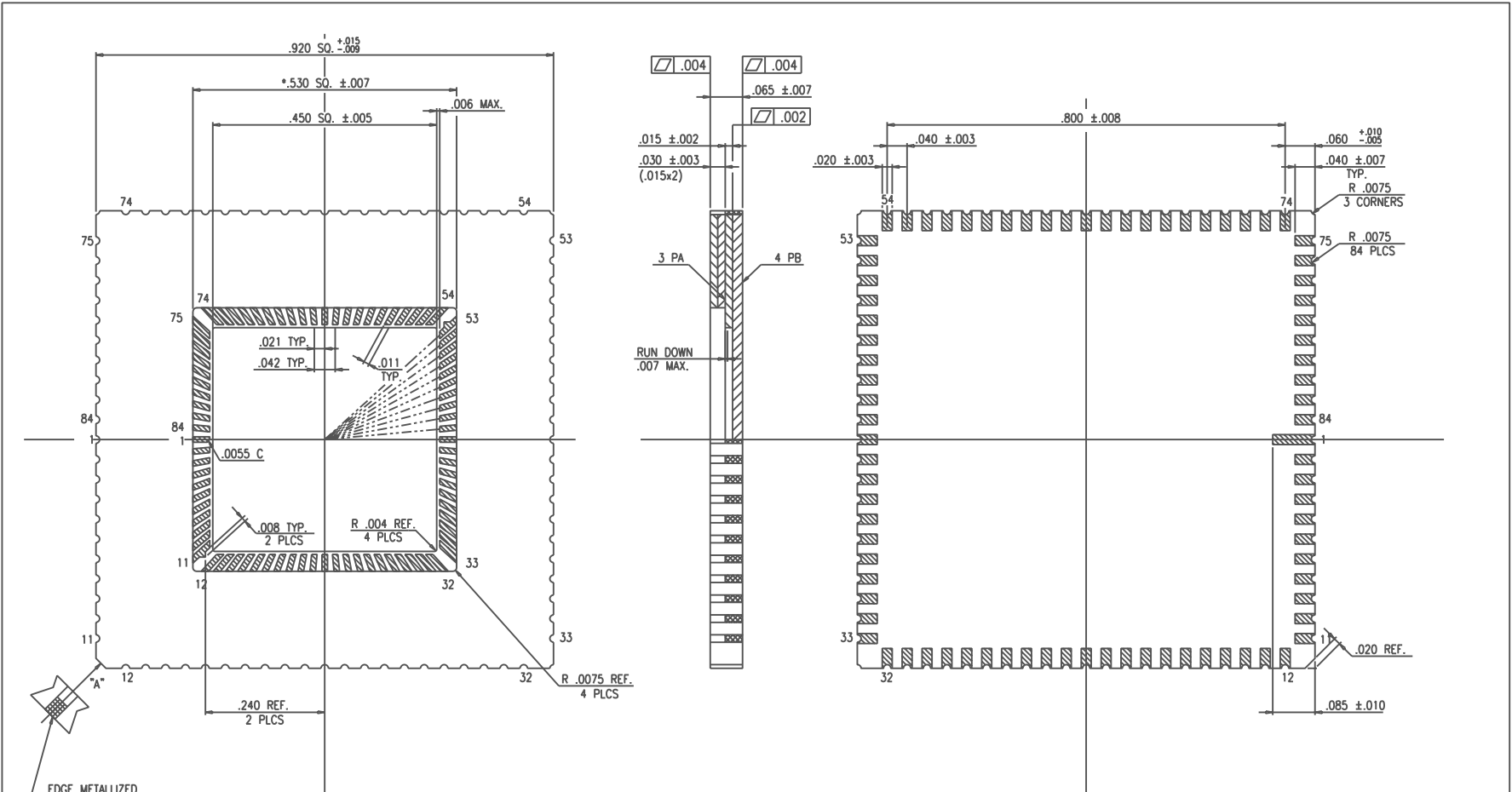

EDGE METALLIZED
VIEW "A"

- NOTE
1. ALL EXPOSED METALLIZED AREA SHALL BE GOLD PLATED 60? INCH MIN THK OVER NICKEL PLATED UNLESS OTHERWISE SPECIFIED PURCHASE ORDER.
 2. SEAL AREA AND DIE ATTACH AREA SHALL BE WITHOUT METALLIZATION.
 3. * INDICATES DIMENSION OF THE TOP LAYER.

S=N
D=N

MODIFICATIONS	NAME	84 LCC (.450 SQ. CAV.)		TOLERANCES:	DRAWN	CHECKED	APPROVED	DATE
	SCALE	7/1	MATERIAL	UNLESS OTHERWISE SPECIFIED	M.H	U.E.	K.H	M.S
			KYOCERA A-440	$\pm .005$				JAN.25.'01
				THIRD ANGLE PROJECTION				
CHANGE	DATE	DRAWN	CHECKED	APPROVED	DRAWING NO.			SHEET
					PB-CA1078			1/3
				KYOCERA		KYOCERA CORPORATION		
				KYOTO JAPAN				

PB-81806-A (RCA-84C) MOD.



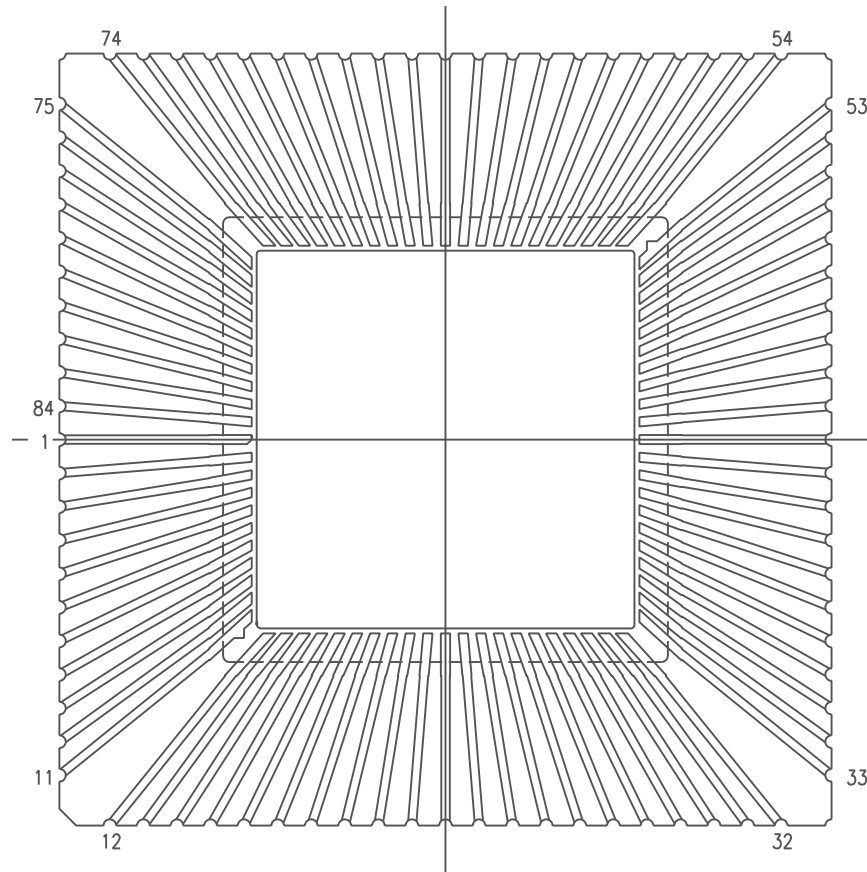

3 PA

MODIFICATIONS						NAME	84 LCC (.450 SQ. CAV.)	TOLERANCES:	DRAWN	CHECKED	APPROVED	DATE	
						SCALE	10/1	UNLESS OTHERWISE SPECIFIED	M.H	U.E.	K.H	M.S	JAN.25.'01
						MATERIAL							
								THIRD ANGLE PROJECTION					
	CHANGE	DATE	DRAWN	CHECKED	APPROVED		KYOCERA CORPORATION KYOTO JAPAN		DRAWING NO.		SHEET		
									PB-CA1078		2/3		



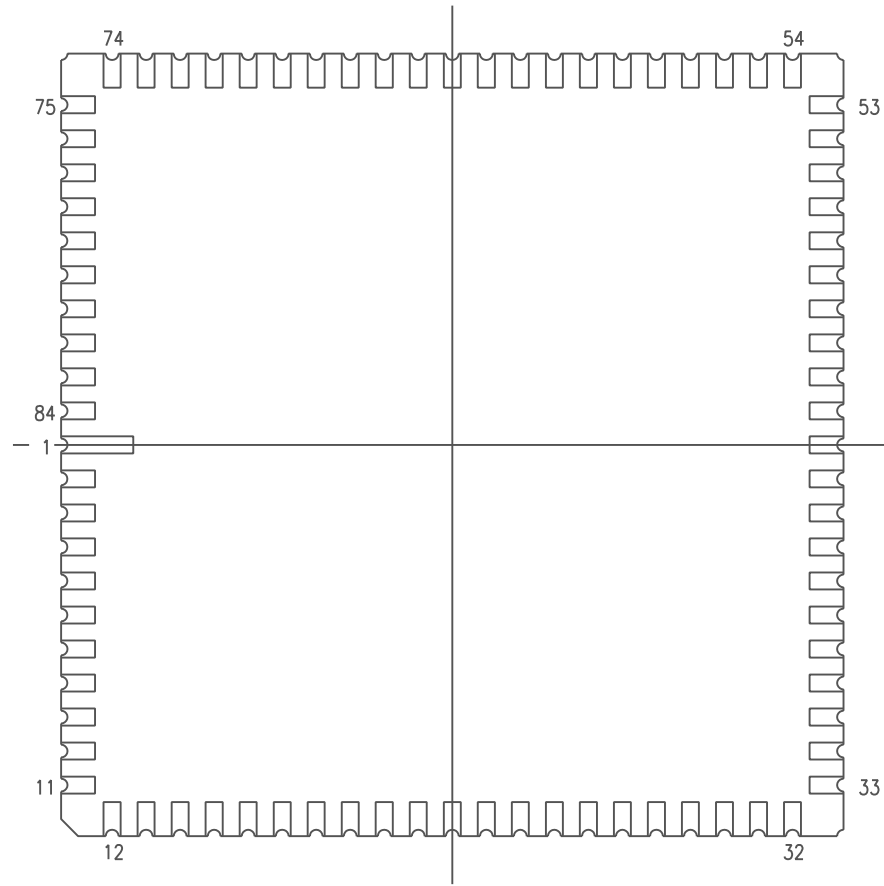

4 PB
 (TOP VIEW)

MODIFICATIONS					NAME	84 LCC (.450 SQ. CAV.)	TOLERANCES: UNLESS OTHERWISE SPECIFIED	DRAWN	CHECKED	APPROVED	DATE	
					SCALE	10/ 1	MATERIAL	M.H	UC	K.H	M.S	JAN.25.'01
							THIRD ANGLE PROJECTION					
	CHANGE		DATE	DRAWN	CHECKED	APPROVED		KYOCERA CORPORATION KYOTO JAPAN		DRAWING NO.	PB-CA1078	SHEET 3/3



