

NOTES;

1. ALL EXPOSED METALLIZED AREA SHALL BE GOLD PLATED 80 MICRO INCHES MIN. THICKNESS OVER COPPER PLATED 50-350 MICRO INCHES, UNLESS OTHERWISE SPECIFIED IN THE PURCHASE ORDER.
2. FLATNESS METALLIZED PAD'S ONLY.
3. SEAL AREA AND DIE ATTACH AREA SHALL BE ISOLATED FROM ANY LEAD'S. (ZERO GROUND)
4. KYOCERA STANDARD SPEC AS-1003-B SHALL BE APPLIED EXCEPT FOR ITEM2 (BAKING TEST).
 a) BAKING TEST;
 GOLD PLATING SHALL NOT SHOW BLISTERS, PEELING OR FLAKING, WHEN VIEWED BY NAKED EYE AFTER BAKING TEST USING HEATER BLOCK AT 350 DEGREE C FOR 1 MINUTE IN AIR ATMOSPHERE. DISCOLORATION OF GOLD PLATING SHALL BE ACCEPTABLE.
5. THIS PACKAGE CONSIST OF "NOT FERROMAGNETISM MATERIAL", WHICH ARE DIAMAGNETISM, PARAMAGNETIC AND ANTIFERROMAGNETIC MATERIALS, WHICH DOESN'T NECESSARILY MEAN ZERO TESLA.

S=0
D=0

MODIFICATIONS						
	CHANGE		DATE	DRAWN	CHECKED	APPROVED

NAME	28 LCC (.290 SQ. CAV.)	TOLERANCES: UNLESS OTHERWISE SPECIFIED	DRAWN	CHECKED	APPROVED	DATE
SCALE	8 / 1	± .005	H.S	S.S/H.K	M.T	MAR.08.'18
MATERIAL	KYOCERA A440	THIRD ANGLE PROJECTION	DRAWING NO.			SHEET
KYOCERA	KYOCERA CORPORATION KYOTO JAPAN		PB-CB8230			1 / 5

PB-45033-C MOD.



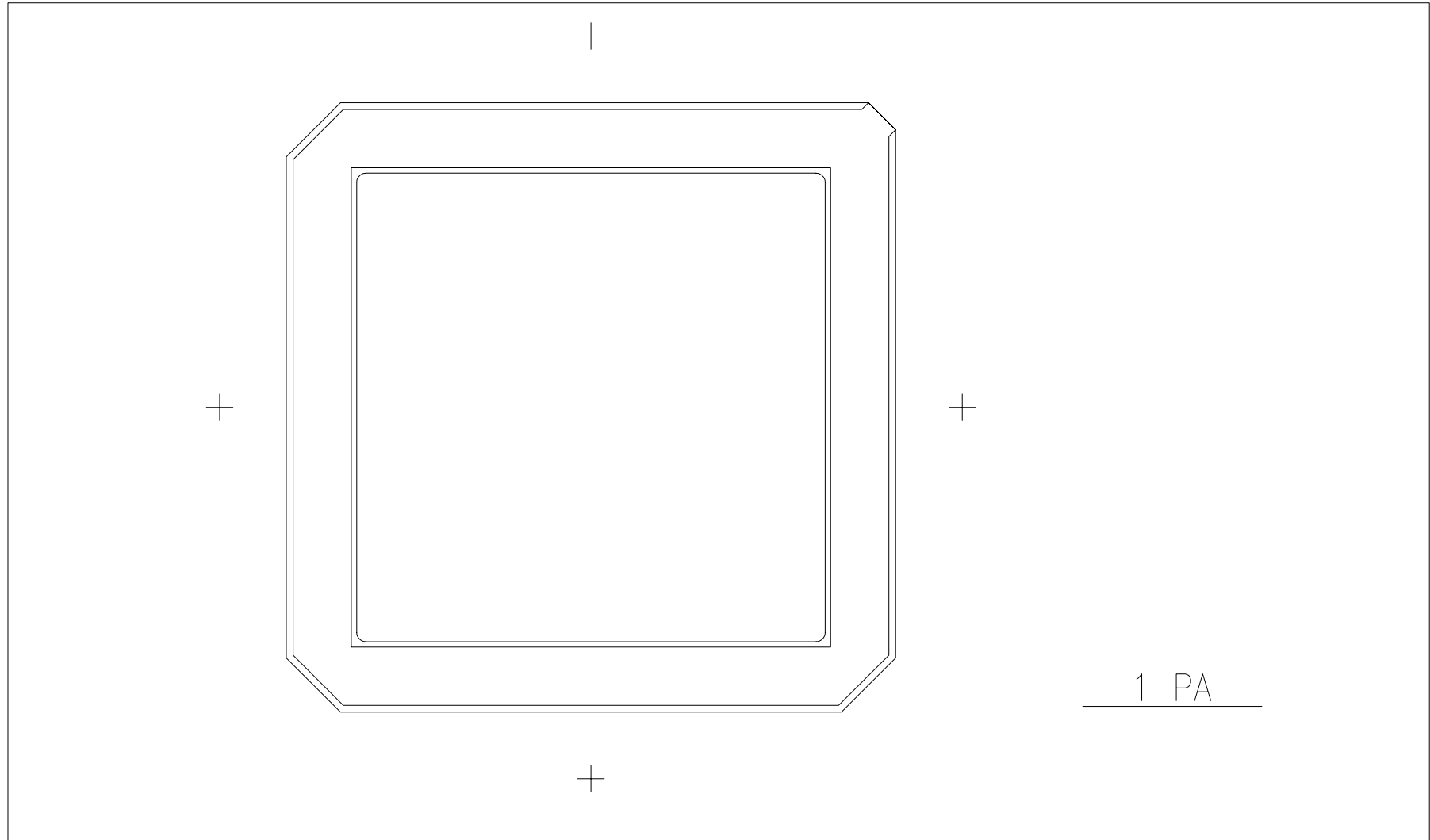

1 PA

MODIFICATIONS						NAME	28 LCC (.290 SQ. CAV.)	TOLERANCES: UNLESS OTHERWISE SPECIFIED	DRAWN	CHECKED	APPROVED	DATE
						SCALE	15/1		H.S	S.S/H.K	M.T	MAR.08.'18
							MATERIAL	THIRD ANGLE PROJECTION	H.S	S.S H.K	M.T	
	CHANGE	DATE	DRAWN	CHECKED	APPROVED		KYOCERA CORPORATION KYOTO JAPAN	DRAWING NO.	PB-CB8230		SHEET	2/5



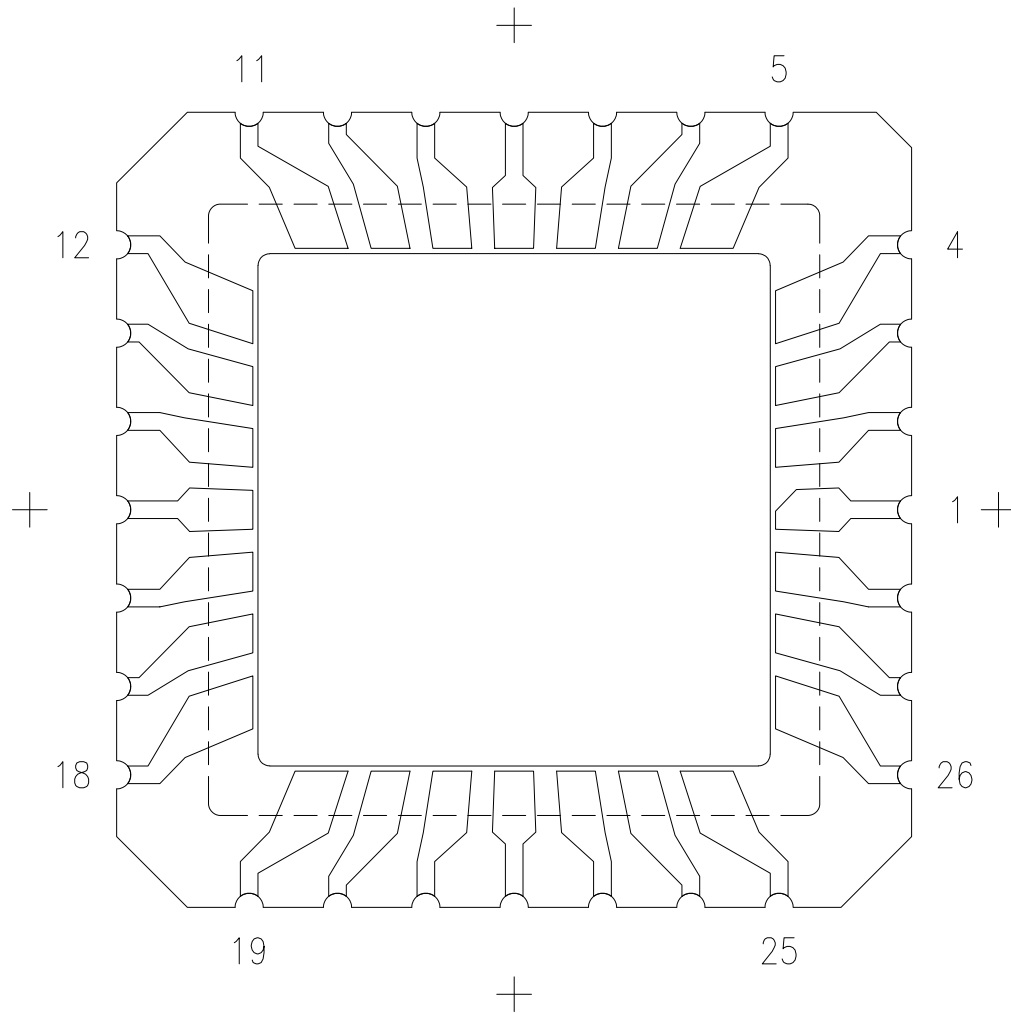

MODIFICATIONS						NAME	28 LCC (.290 SQ. CAV.)	TOLERANCES: UNLESS OTHERWISE SPECIFIED	DRAWN	CHECKED	APPROVED	DATE
						SCALE	15/1		H.S	S.S/H.K	M.T	MAR.08.'18
						MATERIAL		THIRD ANGLE PROJECTION	H.S	S.S H.K	M.T	
	CHANGE	DATE	DRAWN	CHECKED	APPROVED		KYOCERA CORPORATION KYOTO JAPAN	DRAWING NO.	PB-CB8230		SHEET	3/5



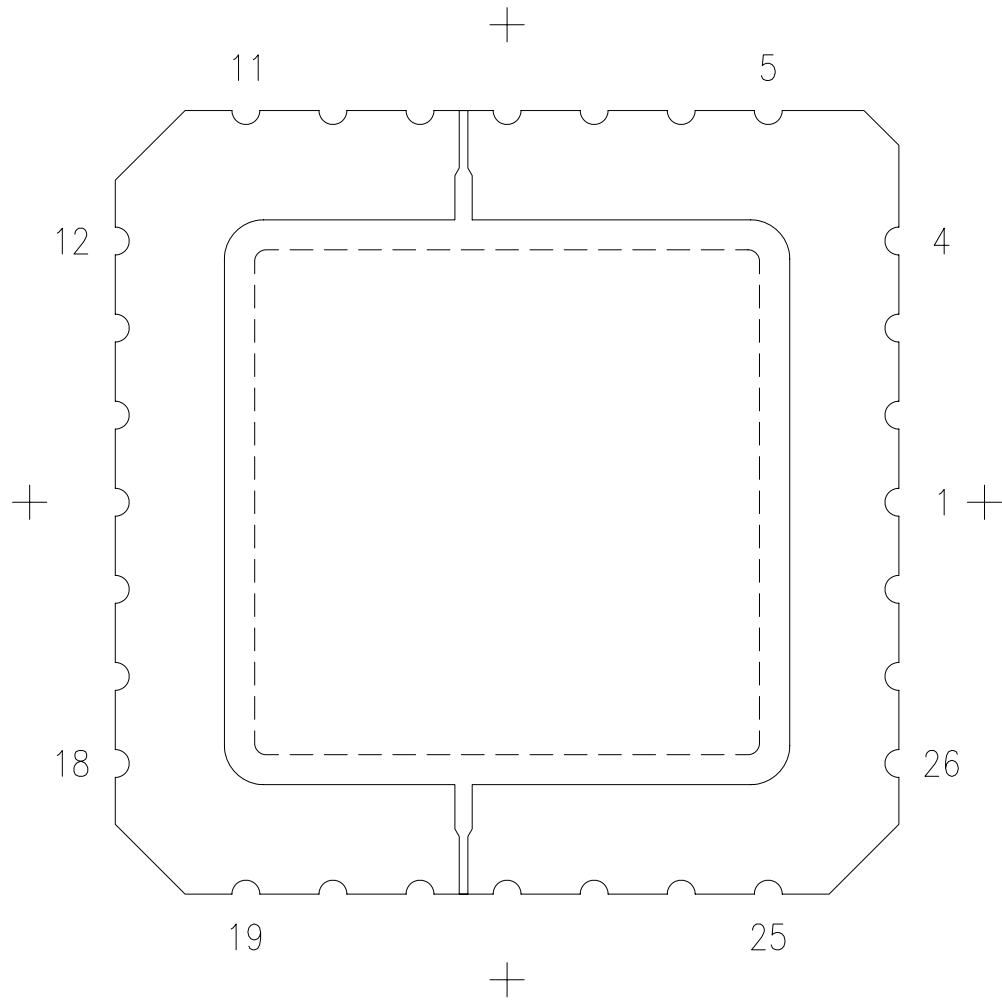

3 PA

MODIFICATIONS						NAME	28 LCC (.290 SQ. CAV.)	TOLERANCES: UNLESS OTHERWISE SPECIFIED	DRAWN	CHECKED	APPROVED	DATE
						SCALE	15/1		H.S	S.S/H.K	M.T	MAR.08.'18
						MATERIAL		THIRD ANGLE PROJECTION	H.S	S.S H.K	M.T	
	CHANGE	DATE	DRAWN	CHECKED	APPROVED		KYOCERA CORPORATION KYOTO JAPAN	DRAWING NO.	PB-CB8230		SHEET	4/5



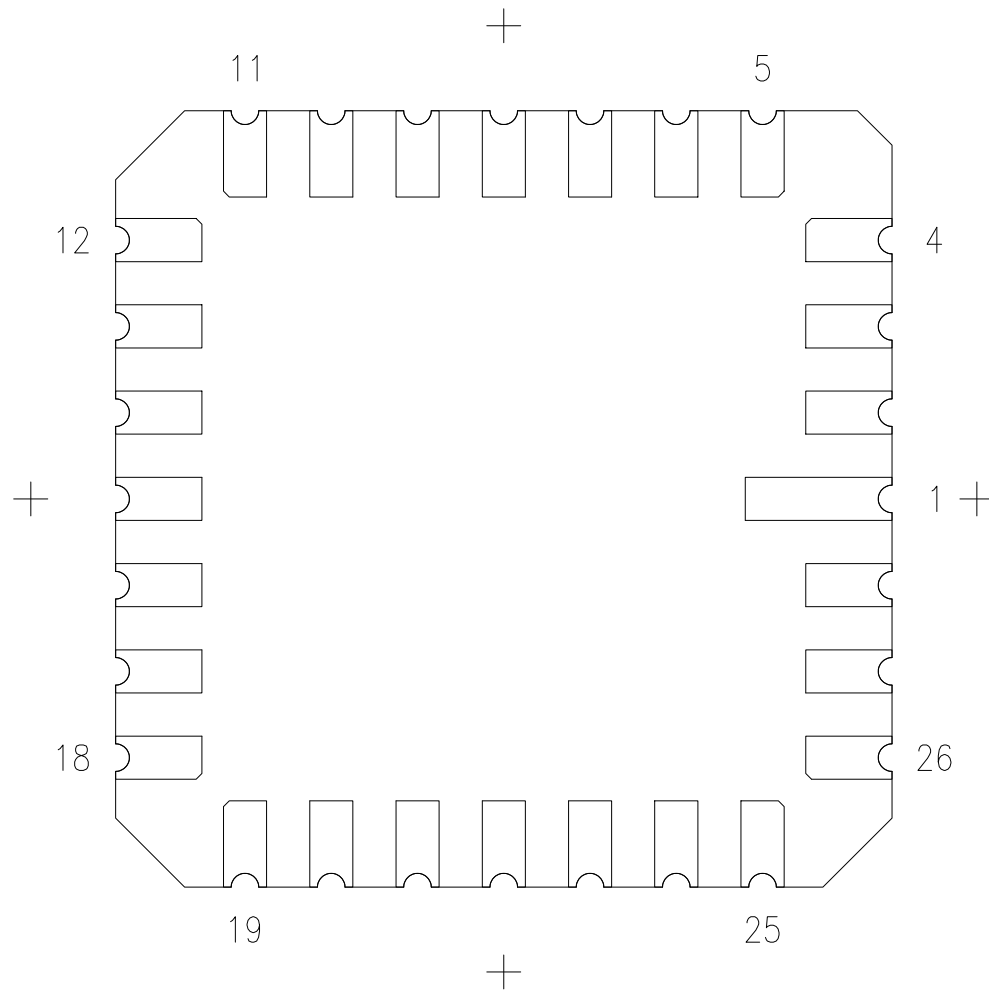

3 PB
(TOP VIEW)

MODIFICATIONS					NAME	28 LCC (.290 SQ. CAV.)	TOLERANCES: UNLESS OTHERWISE SPECIFIED	DRAWN	CHECKED	APPROVED	DATE
					SCALE	15/1		H.S	S.S/H.K	M.T	MAR.08.'18
						MATERIAL	THIRD ANGLE PROJECTION	H.S	S.S H.K	M.T	
	CHANGE	DATE	DRAWN	CHECKED	APPROVED	KYOCERA	KYOCERA CORPORATION KYOTO JAPAN	DRAWING NO.	PB-CB8230		SHEET 5/5

