

SSM P/N HDR00544

MASTER 1.8.10-6

REV	DATE	REVISION
A7		REDRAWN
		CHANGE
AS		ADDED NOT

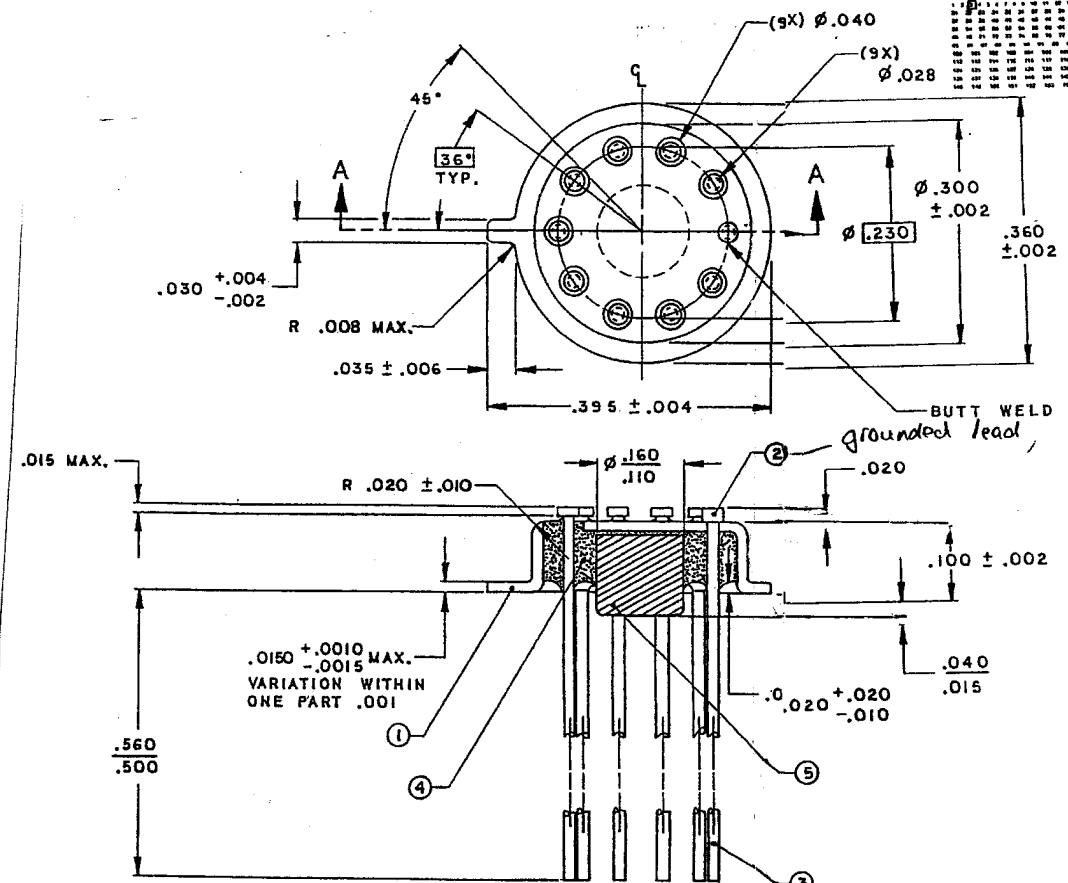

NOTES: (UNLESS OTHERWISE SPECIFIED),
 ① REQUIREMENTS MUST BE ACCORDANCE WITH MATERIAL AND SUPPLY SPECIFICATION 72.
 ② STAND-OFF MUST NOT BE IN DIRECT CONTACT WITH METAL EYELET.
 ③ PLATING OPTIONS:

STOCK No.	GOLD THICKNESS	NICKEL
7284	50 TO 120 μ" IN DIE ATTACH AREA, 50 TO 225 μ" ON LEADS	50 - 350 μ" (ELECTROLYTIC SULFAMATED)
7334	SPOT PLATE 50 TO 120 μ" ON D/A AREA	50 - 350 μ" (ELECTROLYTIC SULFAMATED)

(10x) ∅ .017 ± .002
 -.001

SECTION A-A

TABLE A

NUMBER	DESCRIPTION
1	EYELET (KOVAR) TYPE A
2	GROUND LEAD (KOVAR) TYPE A
3	LEAD (KOVAR) TYPE A
4	GLASS (HARD GLASS)
5	STAND-OFF (GLASS CERAMIC)

ANGELO SILVA 6/89	DATE
DRAWN	
REDESIGNED	DATE
CHECKED	DATE
APP FOR PRODUCTION	DATE
FINISH	DATE
SEE TABLE A	
MATERIAL	DATE
012	DATE
SPECIFICATION	DATE

TITLE TO-5 N HEAD + 10 LEAD
 SCALE 10X
 PAGE 1 OF 1

4. GLASS COLOR TO BE BLACK OR DARK BROWN.



SPECTRUM
 SEMICONDUCTOR MATERIALS, INC.

www.spectrum-semi.com Phone: 408-435-5555 Fax: 408-435-8226