

- NOTES:
1. PLATING :  
Au : 60 MICRO INCHES [1.524 MICRON] MIN.
  2. BAKING TEST:  
BLISTER AND PEELING NOT TO BE ALLOWED  
AFTER 350 +10/-0 °C FOR 180 +30/-0 SECONDS IN OVEN.  
(DISCOLORATION TO BE ALLOWED)
  3. DIE ATTACH PAD TO BE FLOATING FROM ANY LEADS.
  4. WIRE BOND PAD CONNECTED TO CORRESPONDED OUTER LEADS.
  5. OPEN CHECK TO BE CONDUCTED BY VISUAL INSPECTION OF ELECTROLYTIC PLATING.
  6. MISALIGNMENT OF METALLIZATION PATTERN IN CAVITY SHALL BE ACCEPTED DUE TO LAYER MISALIGNMENT.
  7. LEAD RESISTANCE : 0.20 OHM MAX.
  8. COLOR HUE VARIATION OF Au PLATING SURFACE TO BE ALLOWED.
  9. EXCESS Au PLATING AT PACKAGE SIDE IS ACCEPTABLE.
  10. DIMENSIONS ARE IN INCHES[MILLIMETERS]. THE CONTROLLING DIMENSIONS ARE IN INCHES. METRIC DIMENSIONS ARE FOR REFERENCE ONLY.

**KYOCERA CONFIDENTIAL**

MODIFICATION					APPROVALS			SCALE 5 / 1	PART NO.
					DRAWN	CHECKED	APPROVED	TOLERANCE UNLESS OTHERWISE SPECIFIED ±.005[0.13]	NAME 16 LEAD SIDE BRAZED PACKAGE
REV.	FIRST REVISION.	DATE '16.10.11	H.K./T.O.H	K.Y	M.I	KYOCERA CORPORATION KYOTO JAPAN		DRAWING NO. KD-SB6M29	REV. -
HISTORY						MATERIAL AS INDICATED		SHEET 1 / 6	

A3(297X420)



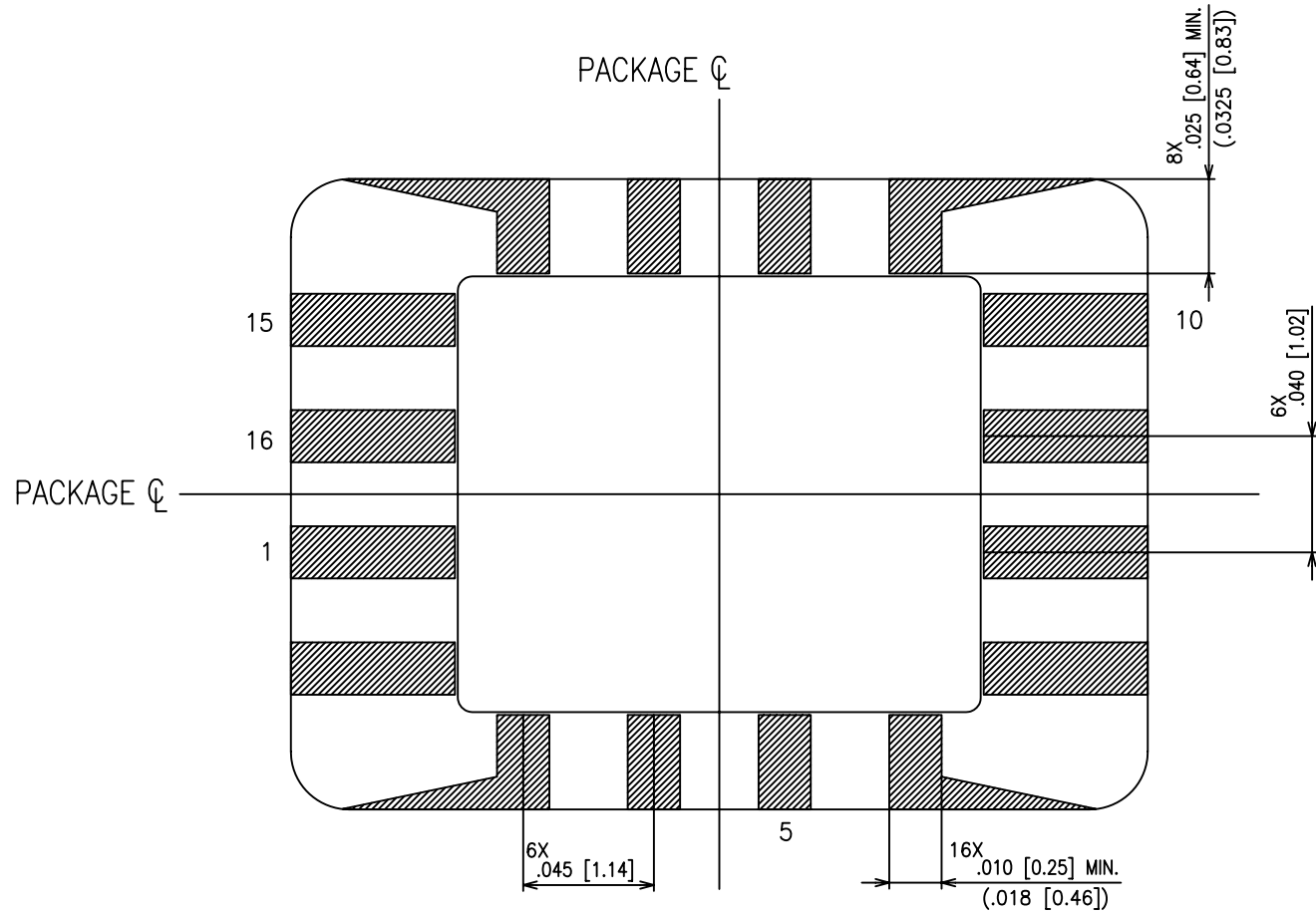

BONDING PATTERN

**KYOCERA CONFIDENTIAL**

MODIFICATION						APPROVALS			SCALE 25/1	PART NO.	
						DRAWN	CHECKED	APPROVED	TOLERANCE UNLESS OTHERWISE SPECIFIED	NAME 16 LEAD SIDE BRAZED PACKAGE	
						'16.10.11 H.K./TO.H			THIRD ANGLE PROJECTION		
REV.	HISTORY	DATE	DRAWN	CHECKED	APPROVED	KYOCERA CORPORATION KYOTO JAPAN		MATERIAL	DRAWING NO. KD-SB6M29	REV. -	SHEET 2/6

A3(297X420)



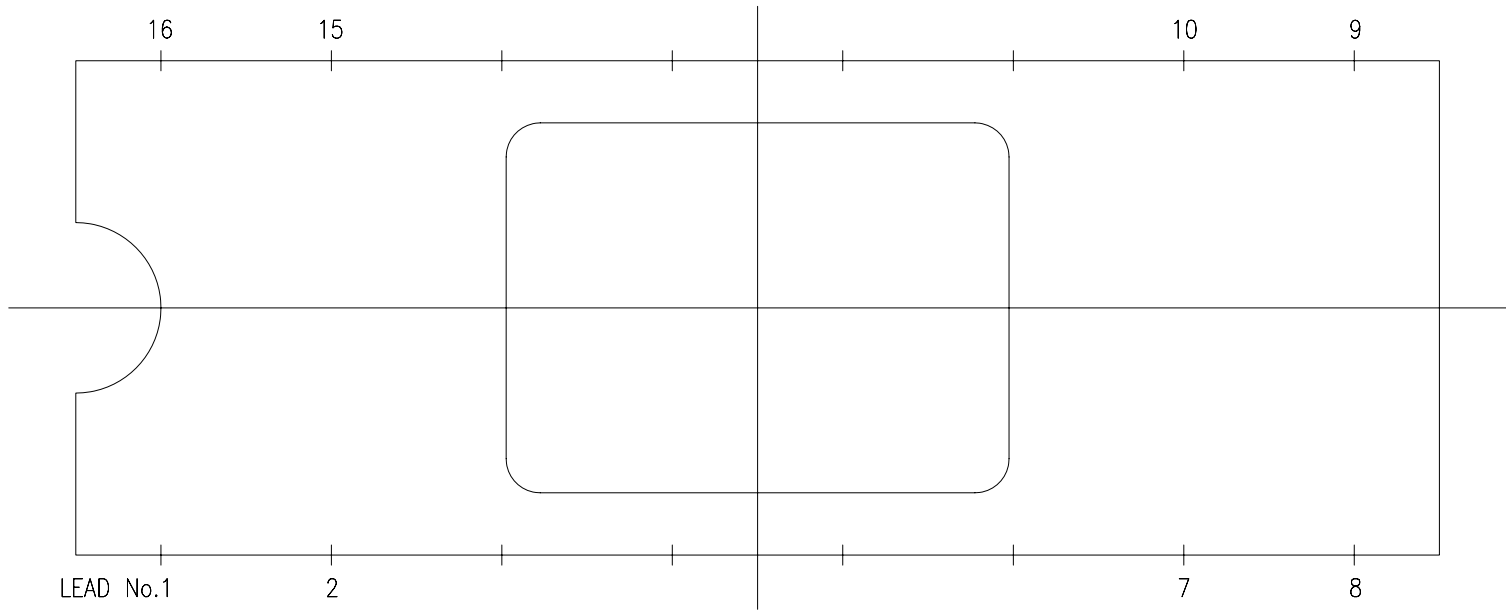

LAYER - 1

**KYOCERA CONFIDENTIAL**

MODIFICATION						APPROVALS			SCALE 15/1	PART NO.
						DRAWN	CHECKED	APPROVED	TOLERANCE UNLESS OTHERWISE SPECIFIED	NAME 16 LEAD SIDE BRAZED PACKAGE
						'16.10.11 H.K./T.O.H			THIRD ANGLE PROJECTION	DRAWING NO.
	— FIRST REVISION.	'16.10.11	H.K./T.O.H	K.Y	M.I	<b>KYOCERA</b>	KYOCERA CORPORATION KYOTO JAPAN		MATERIAL	REV. —
REV.	HISTORY				DATE	DRAWN	CHECKED	APPROVED		DRAWING NO. KD-SB6M29

A3(297X420)



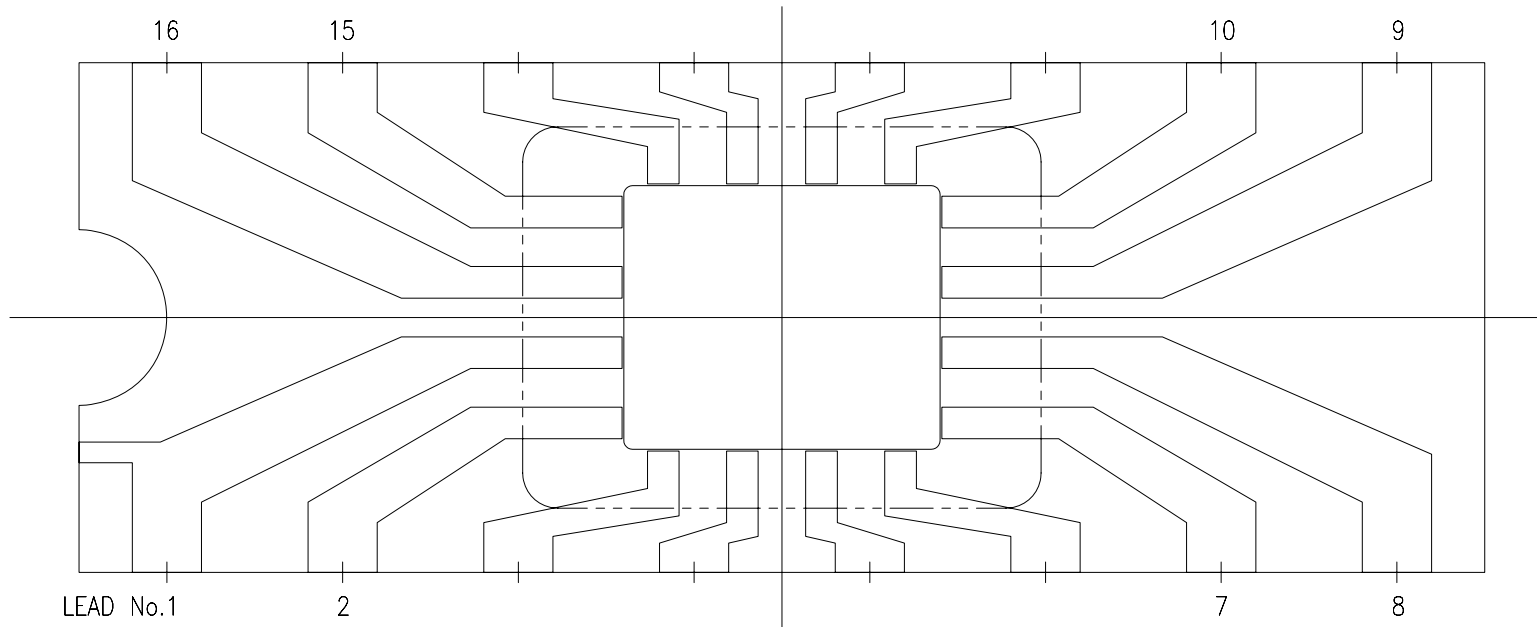

MP-2

**KYOCERA CONFIDENTIAL**

MODIFICATION						APPROVALS			SCALE 15/1	PART NO.
						DRAWN	CHECKED	APPROVED	TOLERANCE UNLESS OTHERWISE SPECIFIED	NAME 16 LEAD SIDE BRAZED PACKAGE
						'16.10.11 H.K./TO.H			THIRD ANGLE PROJECTION	DRAWING NO.
	— FIRST REVISION.	'16.10.11	H.K./TO.H	K.Y	M.I	<b>KYOCERA</b>		KYOCERA CORPORATION KYOTO JAPAN	MATERIAL	KD-SB6M29
REV.	HISTORY	DATE	DRAWN	CHECKED	APPROVED					REV. —
										SHEET 4/6

A3(297X420)



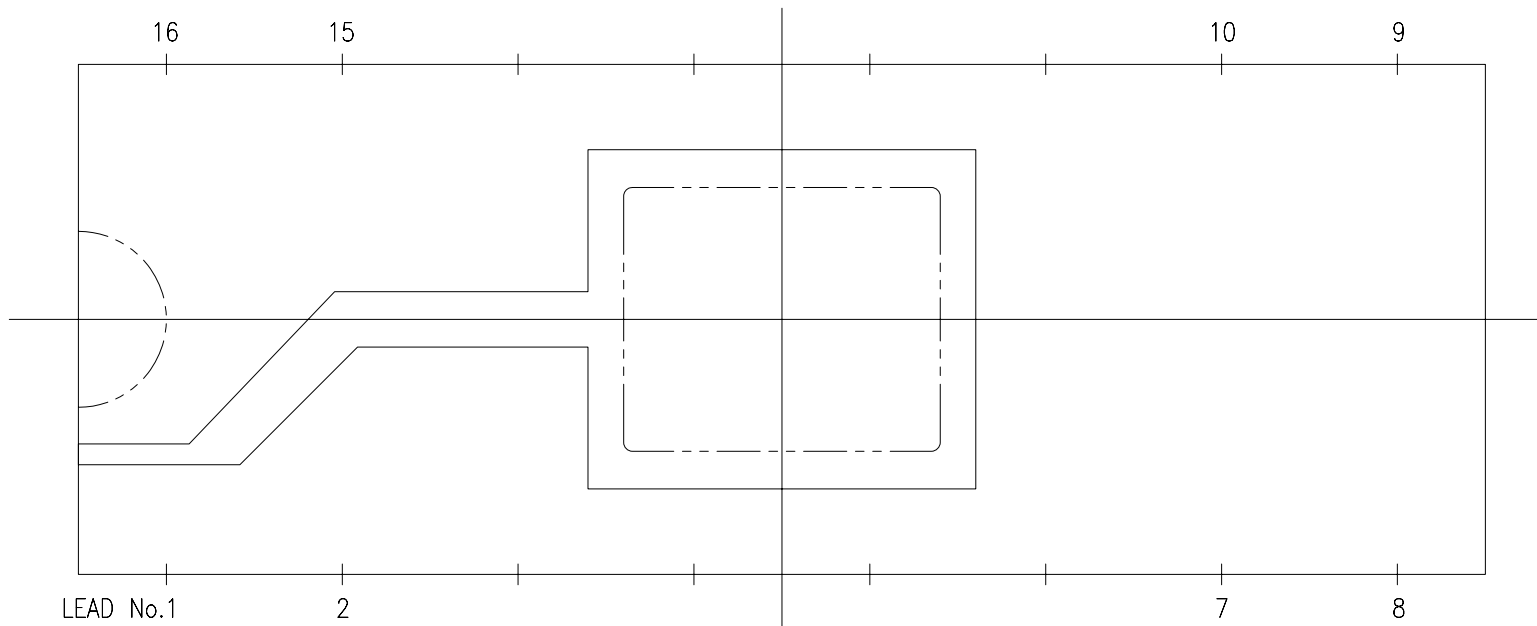

MP-3

**KYOCERA CONFIDENTIAL**

MODIFICATION						APPROVALS			SCALE 15/1	PART NO.
						DRAWN	CHECKED	APPROVED	TOLERANCE UNLESS OTHERWISE SPECIFIED	NAME 16 LEAD SIDE BRAZED PACKAGE
						'16.10.11 H.K./TO.H			THIRD ANGLE PROJECTION	DRAWING NO. KD-SB6M29
	—	FIRST REVISION.	'16.10.11	H.K./TO.H	K.Y	M.I	<b>KYOCERA</b> KYOCERA CORPORATION KYOTO JAPAN		MATERIAL	REV. —
REV.	HISTORY	DATE	DRAWN	CHECKED	APPROVED					

A3(297X420)



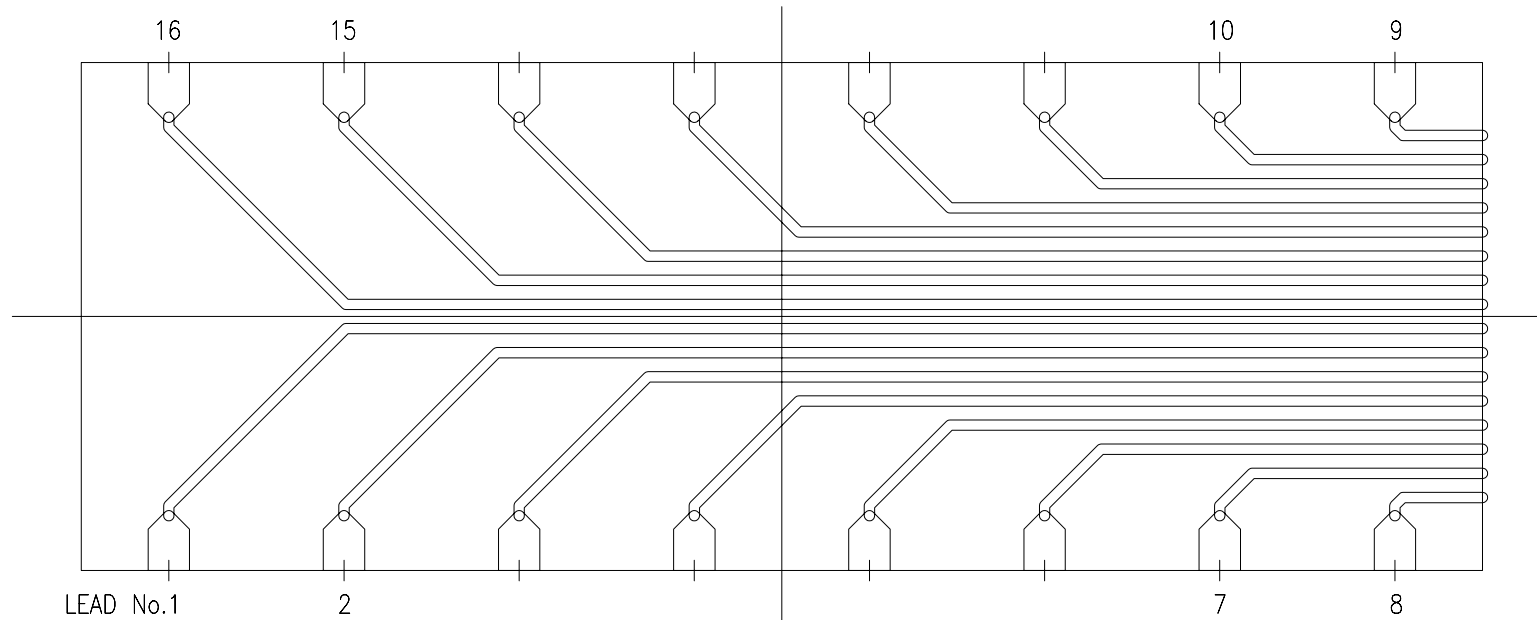

MP-4

**KYOCERA CONFIDENTIAL**

MODIFICATION							APPROVALS			SCALE 15/1	PART NO.	
							DRAWN	CHECKED	APPROVED	TOLERANCE UNLESS OTHERWISE SPECIFIED	NAME 16 LEAD SIDE BRAZED PACKAGE	
							'16.10.11 H.K./TO.H			THIRD ANGLE PROJECTION		
	FIRST REVISION.	'16.10.11	H.K./TO.H	K.Y	M.I		KYOCERA CORPORATION KYOTO JAPAN			DRAWING NO.	REV.	SHEET
REV.	HISTORY	DATE	DRAWN	CHECKED	APPROVED					KD-SB6M29	-	6/6

A3(297X420)



