

# SSM P/N CR-38501

REVISIONS			
ECN NO.	DATE	DESCRIPTION	APPROVED
		PRODUCTION RELEASE	

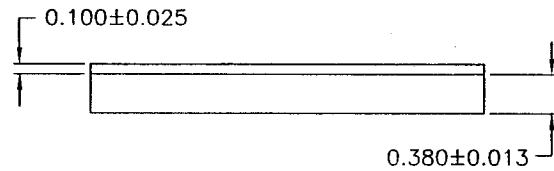
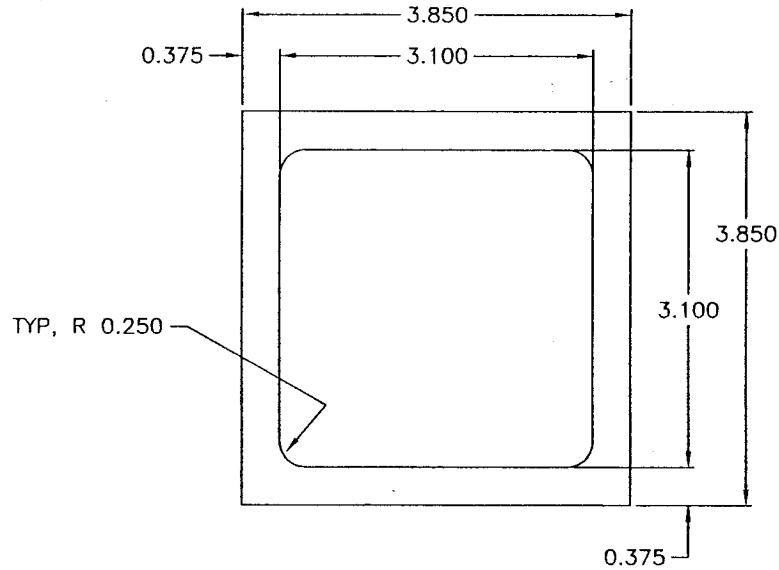

**NOTES:**

- MATERIAL:  
 (A) LID: Al<sub>2</sub>O<sub>3</sub> CERAMIC-BLACK, 0.380 THK.  
 (B) PREFORM: SI 100 EPOXY.
- RECOMMENDED CURE: 30 MINUTES @ 175°C.

THIRD ANGLE PROJECTION	DRAWN BY	DATE
	APP BY	DATE
UNLESS OTHERWISE SPECIFIED DIMENSIONS ARE IN MILLIMETERS TOLERANCES ARE: X.XX ± 0.015 X.XXXX ± --- X.XXX ± 0.050 ANGLES: ± 1°	CUSTOMER	
DO NOT SCALE DRAWING		

4mm x 4mm MLP  
Ceramic Lid

**CR-QFN4X4-15-01 REV 2**

