

SSM P/N CAN00815W

Produktspezifikation:
SL 10.006.901

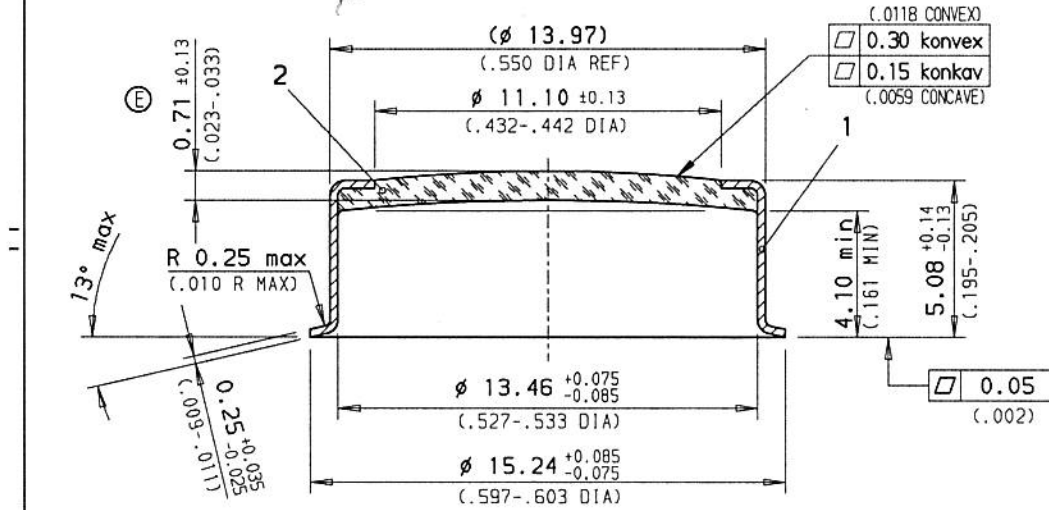

- 1 NiCo2918.
(KOVAR)
- 2 Klarglas
(CLEAR-GLASS)

(IN KLAMMERN-INCH MASSE)

E	1x/071126/12	26.11.07	Prn	Freimaßtoleranzen	Oberfläche: che Ni 2-3 um		
				Form- und Lagetoleranzen	FINISH: ELECTROLESS NI 80-120 µ"		
				DIN EN 150 1101			
				Datum	Name	Fensterkappe	T08
				Bearb.	Prn	WINDOW-CAP T08	Maßstab 5:1
				Gepr.	FLa		Blatt 1
				Norm.	Gp		von 1
				SCHOTT		SL 10.055.006	E
				TOTAL CUSTOMER CARE		Ersatz für:	950710/4
Ausgabe	Änderung	Datum	Name				PM 1 DIN 6

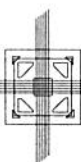

SPECTRUM
SEMICONDUCTOR MATERIALS, INC.

www.spectrum-semi.com Phone: 408-435-5555 Fax: 408-435-8226

Glass 8250

Technical Data

GlassType/Application Borosilicate glass for sealing to KOVAR metal and molybdenum, electrically highly insulating
X-ray tubes, transmitting tubes, image amplifier tubes, He-Ne-laser, clad tube for optical fibres, ozone generators

Physical Data			
Coefficient of mean linear thermal expansion			
$\alpha(20^{\circ}\text{C}; 300^{\circ}\text{C})$ (ISO 7991)	5.0	10^{-6}K^{-1}	
Transformation temperature T_g (ISO 7884-8).....	490	$^{\circ}\text{C}$	
Glass temperature at viscosity η in $\text{dPa}\cdot\text{s}$			
10^{13} (annealing point) (ISO 7884-4).....	500	$^{\circ}\text{C}$	
$10^{7.6}$ (softening point) (ISO 7884-3).....	720	$^{\circ}\text{C}$	
10^4 (working point) (ISO 7884-2).....	1055	$^{\circ}\text{C}$	
Stress-optical coefficient K (DIN 52314).....	3.6	$10^{-6}\text{mm}^2\cdot\text{N}^{-1}$	
Density ρ at 25°C	2.28	$\text{g}\cdot\text{cm}^{-3}$	
Modulus of elasticity E (Young's modulus)	64	$10^3\text{N}\cdot\text{mm}^{-2}$	
Poisson's ratio μ	0.21		
Thermal conductivity λ_w at 90°C	1.2	$\text{W}\cdot\text{m}^{-1}\cdot\text{K}^{-1}$	
Log of the electric volume resistivity ($\Omega\cdot\text{cm}$)			
at 250°C	10.0		
at 350°C	8.3		
t_{k100}	375	$^{\circ}\text{C}$	
Dielectric constant ϵ for 1 MHz at 25°C	4.9		
Dielectric loss factor $\tan \delta$ for 1 MHz at 25°C	22	10^{-4}	
Refractive index n_d ($\lambda = 587.6 \text{ nm}$)	1.487		

Chemical Resistance			
Hydrolytic resistance (ISO 719)	Class	HGB 3	
Acid resistance (DIN 12116)	Class	S 4	
Alkali resistance (ISO 695)	Class	A 3	

The heavy metal content for the elements lead, cadmium, mercury and hexavalent chromium is below 100 ppm